

RHINO VALVES WORLDWIDE

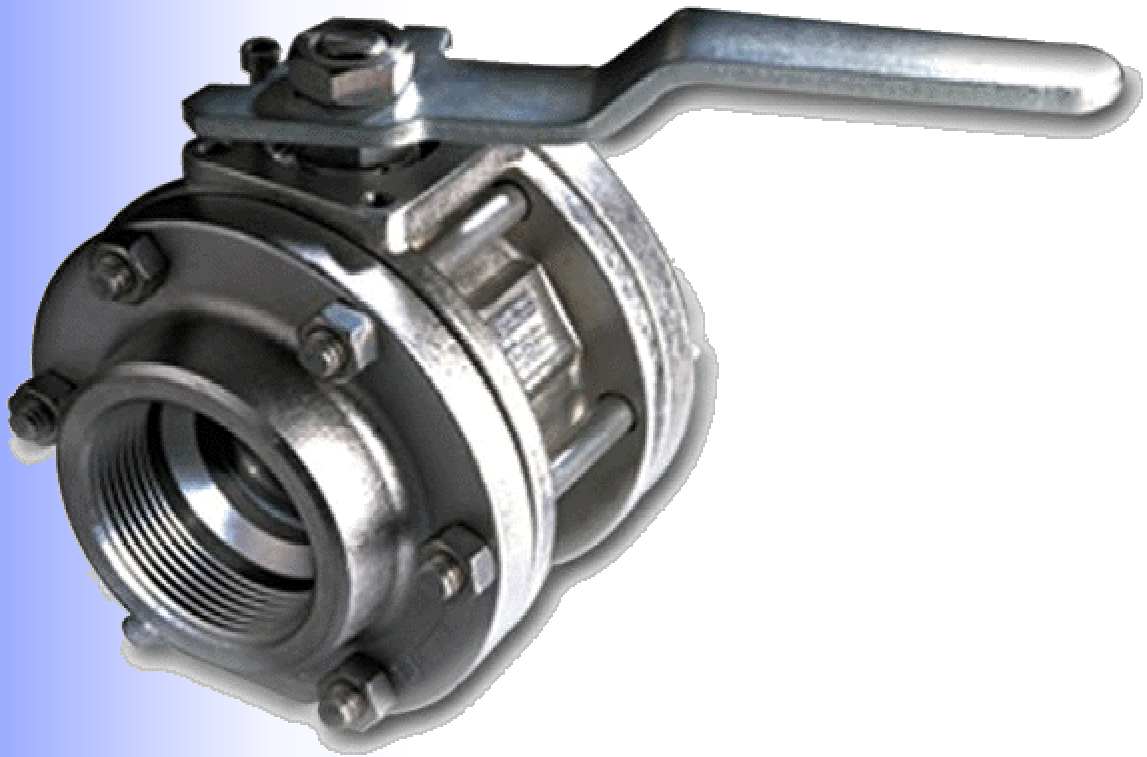

Series 45

**Covering the biggest measures in valves
of 3 threaded pieces and socket weld,
with a versatility comparable to the Series 44
but with an operation range ANSI 300 #.**



LICENSE No. 6D-0321



RHINO VALVES WORLDWIDE



SERIES 45

The Series 45 valve is a three piece design offering maximum ease of installation and service.

Ability in system where unions and easy access to lines are necessary. The design allows the center section to swing completely free of the end without having to cut the piping or disturb the line integrity. this means maintenance of seats, seals, and ball is done right in the line. Fully encapsulated body bolts assure and ease proper alignment during re-assembly. This design also allows the Series 45 to double as a union which, when needed, eliminates the need for a separate connection. The simplicity of installation and maintenance makes this valve ideal for a variety of uses including Chemical Industries, Oil and Gas Production. Refining and transmission. Textiles, Pulp and Paper, Pharmaceutical, and Food and Beverage.

SEATS

The design of Worcester/Rhino Valves allows flow pressure in both directions which is transferred to the floating ball. Then, this is pressed against the downstream seat, resulting in a bubble tight sealing. The resilient seats patented by Worcester allow relief the pressure to the upstream seat against the ball, resulting a low torque of operation and a long, soft operation even with high differential pressures. This low torque characteristic, permits a smaller actuator operation, resulting in lower cost. The seats also acts as a ball whipper, as it removes any adhered material to ball for a better sealing.

STEM

The stem is designed for both safety and a long, leak-tight service life. Inserted from the bottom through the cavity, it rests securely against an interior body shoulder.

The stem is held in place by a live loaded retaining system, featuring opposing belleville washers. These flex in response to thermal expansions and contractions and maintain effective sealing pressure as they compensate for normal stem seal wear. The seal can also be easily adjusted in-line by the accessible stem nut. In series 400 and 600, a stem nut retaining clip holds the nut in place and prevents backing off, particularly in high cycle actuated services. In series 152 a CHEVRON^o type external stem seal is provided.

TORQUE

The operating torque of the ball valve is influenced by a number of factors which has to be considered to size a valve for actuation. These factors are divided in Design (type and material of valve seats), and application (pressure, media and frequency of operation).

The torque shown is in function of the pressure, as the friction between the floating ball and the seat is higher as the pressure is incremented.

Note: Our charts were made for reduced port valves (except for Series 152, which can be read directly). If you want to find the torque of a full port valve, please look for the curve of the next higher size, for example if you want to know the torque of a 1" fill port valve, you have to see the 1 1/4" valve readout.

RHINO VALVES WORLDWIDE

SERIES 45



SERIES 45. Pipe ends NPT, BS, SW, BW or Clamp, reduced bore, strong construction in carbon steel and stainless steel. Three piece body design in sizes of 2 1/2", 3" and 4". Maximum pressure of test: 1050 psi, seals for frequent cycle in diverse materials, standard ISO5211 pad. Optional API-6D.

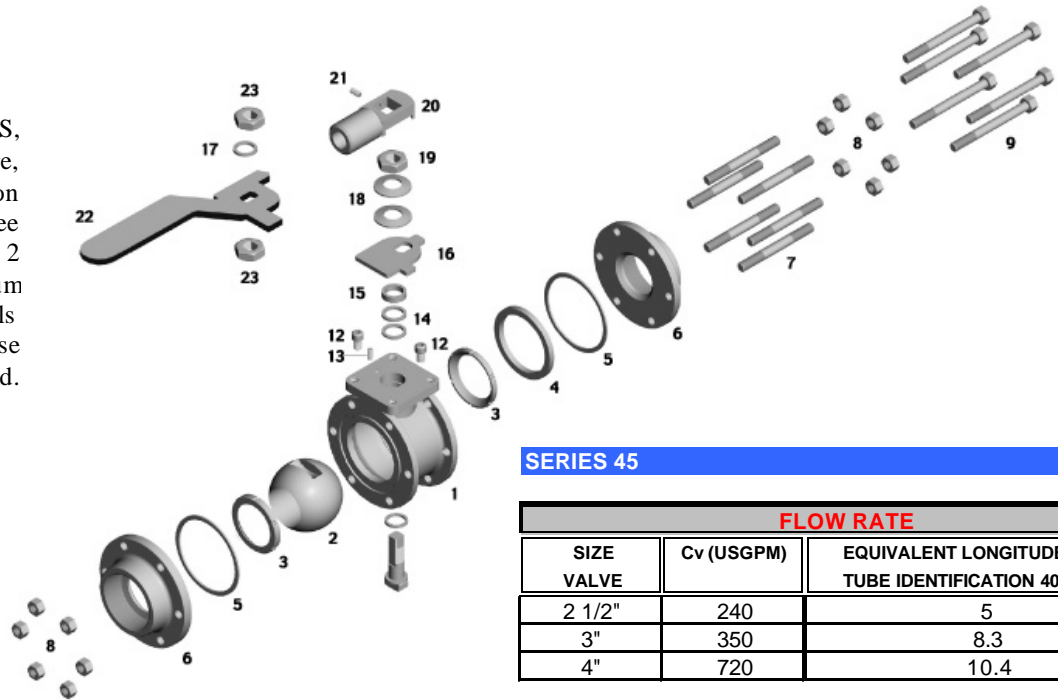

SERIES 45

FLOW RATE		
SIZE VALVE	Cv (USGPM)	EQUIVALENT LONGITUDE OF THE TUBE IDENTIFICATION 40 IN FEET
2 1/2"	240	5
3"	350	8.3
4"	720	10.4

PARTS LISTING OF SERIES 45

ITEM	QUANTITY	DESCRIPTION	MATERIAL	
			CARBON STEEL	STAINLESS STEEL
1	1	BODY	ASTM A 216 WCB	ASTM A 351 CF 8M
2	1	BALL	ASTM A 351 CF 8M	ASTM A 351 CF 8M
3	2	SEAT	PTFE	PTFE
4	1	CENTERING RING	AISI 316	AISI 316
5	2	BODY SEAL	BUNA "N"	BUNA "N"
6	2	PIPE END	ASTM A 216 WCB	ASTM A 351 CF 8M
7	6	STUD (ONLY FOR 3" Y 4")	SAE J 429 GR. 5	ASTM F593 TYPE A304
8	6/12	NUT	ASTM A 194 2HM	ASTM F594 TYPE A 304
9	6	BOLT (ONLY FOR 2 1/2")	SAE J 429 GR. 5	ASTM F593 TYPE A304
10	1	STEM	AISI 1018-12L14	AISI 316
11	1	THRUST BEARING	R-PTFE 25%	R-PTFE 25%
12	2	STOP SCREW (ONLY FOR 3" Y 4")	AISI 1045	AISI 304
13	1	STUD BOLT SCREW (ONLY FOR 2 1/2")	AISI 1045	AISI 304
14	2	SEAL	R-PTFE 15%	R-PTFE 15%
15	1	FOLLOWER	AISI 416	AISI 416
16	1	STOP PLATE	AISI 1018-1020	AISI 1018-1020
17	1	LOCK WASHER (ONLY FOR 2 1/2")	AISI 1060	AISI 304
18	2	BELLEVILLE WASHER	AISI 1075	AISI 302
19	1	STEM NUT (ONLY FOR 3" Y 4")	ASTM A 194 2HM	ASTM F594 TYPE A 304
20	1	HANDLE	ASTM A 216 WCB	ASTM A 351 CF 8M
21	1	SET SCREW (ONLY FOR 3" Y 4")	AISI 1045	AISI 304
22	1	HANDLE (ONLY FOR 2 1/2")	AISI 1018-1020	ASTM A 351 CF 8M
23	1	NUT (ONLY FOR 2 1/2")	ASTM A 194 2HM	ASTM F594 TYPE A 304

RHINO VALVES WORLDWIDE

SERIES 45

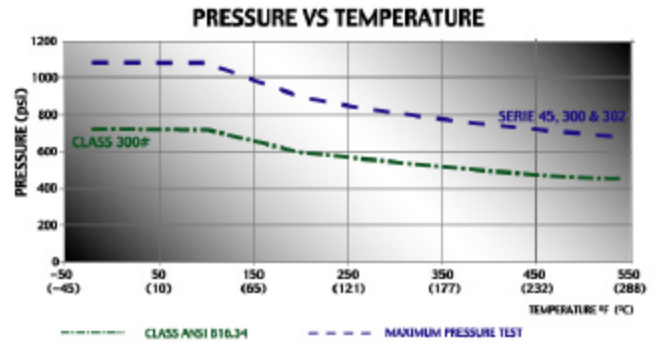
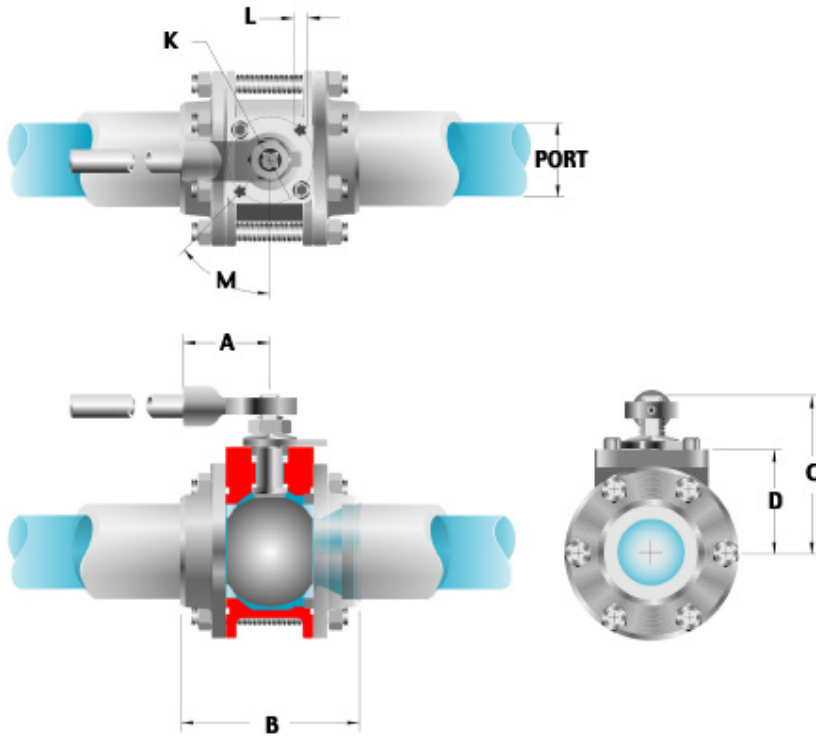

The pipe is exclusively representative. They are only as reference and they are subject to changes without previous notice.

Dimension in inches.

Service Conditions:

CONDITION	CARBON STEEL	STAINLESS STEEL
ANSI CLASS #	300	300
OPERATION TEMPERATURE	-20 to 100°F (-29 to 38°C)	-20 to 100°F (-29 to 38°C)
MAX. ALLOWABLE WORKING PRESSURE	740 psi (52 kg/cm ²)	720 psi (50.6 kg/cm ²)
MAXIMUM PRESSURE TEST	1125 psi (78 kg/cm ²)	1100 psi (76 kg/cm ²)

Note: Always consider the maximum, pressure allowed by the soft elements as seats and seals.

SERIE 45 2 1/2", 3", 4"

SIZE	B16.34 class 300					PLATE ISO 5211					WEIGHT IN Lbs.
	A	B	C	D	PORT	K	L	M			
2 1/2"	7 3/8	5.94	3.98	3.06	2.00	F07	2.755	M8	45°	22.046	
3"	3 1/4	7.00	5.63	3.98	2.50	F10	4.016	M10	45°	33.069	
4"	3 1/4	8.62	6.23	4.58	3.25	F10	4.016	M10	45°	55.116	

RHINO VALVES WORLDWIDE

APPLICABLE INTERNATIONAL STANDARDS



APPLICABLE INTERNATIONAL STANDARDS

Norm	Description	Applicable in	Size	Content
NACE MR-01-75	Valves that require special resistance to fractures and hydrosulfuric attack	All the models except Brass	1/4" - 8"	For sour environment, stainless ferrous and not ferrous metals
ANSI/FCI 70-2	for seat leaks of control valves. Class VI	All the models	1/4" - 8"	(pneumatic) trapped air test
MSS-SP-26	System of Marking Standard	All the models except series 42, 43, 1000	1/4" - 8"	Size-thread-temperature. Pressure-material-Nom. Casting Heat. No.
MSS-SP-55	Visual inspection Method acceptance of cast steel valves	All the models except Brass	1/2" - 8"	12 types of frequent surface irregularities identifiable by comparative visual inspection
API 6D	Specification for piping and valves	All the models	2" - 8"	Quality system according to American Petroleum Institute
API 607	"Fire Safe" testing	All the models except series 42, 43 and 1000	1/4" - 8"	Available certificate in some valves
API 598	Inspection and test of valves	All the models	1/4" - 2"	Hydrostatic and pneumatic inspection
ANSI B 16.5	Flanges for steel pipe lines	All the flanged models	1/2" - 8"	Dimension-material-range. Pressure temperature-facing. Different types of flanges
ANSI B 16.10	End to end dimensions of valves with flanges and/or to weld ends	All the flanged models and weld end models	1/2" - 8"	Face to face Dimensions
ANSI B 16.11	End Dimensions: S.W. (Socket Weld) S.E. (Threaded)	All the models except flanged	1/4" - 6"	Face to face Dimensions
ANSI B 16.34	Steel valves	All the models	1/4" - 14"	Wall Thickness designs. Material-specifications. Range-Pressure-Temperature. Hydrostatic Test
ANSI B 16.25	Buttweld ends	All the models except flanged	1/2" - 6"	Angle of machine beveling and O.D. And I.D.

RHINO VALVES WORLDWIDE



HOW TO ORDER

HOW TO ORDER TO RHINO VALVES

Valve Size	Type	Series	Body, pipe ends	M a t e r i a l			Ends
				Ball Steam	Seat	Body Seals	
1 1/2"	D	4	4	6	T	T	SW
1/4"	- Normal	4 - 400 (44)	1 - Brass	1 - Brass	B - Buna	B - Buna	SE - Screw End
3/8"	FS - Fire Safe	6 - 600	4 - Carbon Steel	4 - Carbon Steel	T - Ptfе	T - Ptfе	SW - Socket Weld
1/2"	D - Diverter	H6 - H600	6 - Stainless Steel	6 - Stainless Steel	R - Tfe	R - Tfe	BW - Butt Weld
3/4"	T - 3 Ways	42 - Mite	6L - Stainless Steel CF-3M		Y - Lubetal (Delrin)	Y - Lubetal (Delrin)	150# - Ansi 150
1"	C - Cryogenic	43 - Mass			MT - Multifil	MT - Multifil	300# - Ansi 300
1 1/4"	PT - Full Port	60 - 6000			U - Uhmwpe	U - Uhmwpe	
1 1/2"		45			D - Devlon	D - Devlon	
2"		150				G - Graphoil	
3"		151				V - Viton	
4"		152					
6"		300					
8"		302					
		10 - 1000					
		20 - 2000					
					Note : Use only one letter if body seal is to be same material as seat		

NOT ALL THE COMBINATIONS ARE AVAILABLE. SEE THE FOLLOWING TABLE AND CONSULT TO THE COMPANY OR AUTHORIZED DISTRIBUTOR FOR AVAILABILITY.

THERE ARE SOME OTHER MATERIALS, OPTIONS AND ENDS AVAILABLE

COMMON COMBINATION FOR SEALS AND SEATS MATERIALS

SERIES	SEATS	BODY SEALS	STEAM SEAL
ALL	BUNA	BUNA	RTFE
ALL	PTFE	PTFE	RTFE
ALL	RTFE	PFTE	RTFE
ALL	LUBETAL	VITON	RTFE
ALL	MULTIFIL	MULTIFIL	MULTIFIL
ALL	UHMWPE	VITON	RTFE
FS ONLY	PTFE	GRAPHOIL	GRAPHOIL
H600 ONLY	DELTRIN	VITON	DELTRIN/MULTIFIL
6000 ONLY	DELTRIN/VITON	VITON	DELTRIN/MULTIFIL



General Dimensions:

DESCRIPTION	Series 45 Ball Valve		
	2 ½"	3"	4"
LENGTH in (mm)	5.94 (151)	7.00 (178)	8.62 (219)
WIDTH in (mm)	5.84 (148)	6.50 (165)	8.13 (207)
HIGH in (mm)	6.9 (175)	8.9 (226)	10.3 (261)
WEIGHT lb (Kg)	22 (10)	33 (15)	55 (25)

INSTALLATION AND OPERATION:

Your valve is bi-directional and you can install it in any position.

It can be operated manually by rotating smoothly the handle 90 degrees. When the handle is parallel with valve line, the valve is opened. At 90 degrees it is in the closed position. Automation devices (optional) can also operate the valve.

Caution : Remember that a Ball Valve is an OPEN/CLOSE device and it is not designed to control the flow. Never leave the valve in a different position from the OPEN or CLOSE position as it will eventually damage the seats, reducing its life.

Actuated valves:

As your valve has an ISO5211 top mounting plate, you can perform following instructions without disassembling the actuator from the valve.

Welded Valves to the pipe by any technique:

If you have a jig of the Valve's body:

1. Take away the Valve's ends, removing the 6 screws that join the body. Place the ends on the jig screwing in them in an adequate way.
2. Weld each extreme to the installation.
3. Assemble the Valve according to the 9 and 10 points of this section

If you don't have a jig of the Valve's body:

4. Weld just some points in each cover of the Valve in the place of the installation for assure it. **Don't heat it excessively.**
5. Remove the screws that support the body and covers except one of them. Open the Valve loosen the last screw, take out the Valve's body from the line rotating outwards.

NOTE: The Valves with a centering ring included in its design (like in some of the firesafe Valves) won't be rotated.



6. Remove the centering ring and the body's seals and seats. Close the Valve and remove the ball, preventing from scratching its surface. Place it over a soft material free of burrs.
7. Return the body to its position on line and assure it diagonally to the covers with 2 screws.



VÁLVULAS WORCESTER DE MÉXICO S.A. DE C.V.
RHINO VALVES WORLDWIDE



MANUAL OF HANDLING, INSTALLATION, OPERATION,
MAINTENANCE AND SAFETY.
SERIES 45 VALVES (2 ½", 3" and 4").

Receiving Inspection.

All valves must be inspected when they arrive at the purchaser site, to verify that no damages have occurred during transportation or handing. Any damage found must be reported immediately.

Handling.

Store the valve in a safety place, free of rain, dust or any agent that can deteriorate it. All our valves are shipped with end protectors, you must keep them until the installation to avoid introduction of dust and other materials to the inside of the valve.

Note : If you plan to stock the valve for a long period of time, we recommend to leave it in the open position to avoid deformation on seats.

GENERAL INFORMATION.

Materials:

DESCRIPTION	CARBON STEEL	STAINLESS STEEL
BODY	A-216-WCB	A-351-CF8M
SEAT	PTFE	PTFE
BALL	A-351-CF8M / AISI 316	A-351-CF8M / AISI 316
CENTERING RING	AISI 316	AISI 316
SEAL	O-RING (Buna)	O-RING (Buna)
PIPE END	A-216-WCB	A-351-CF8M
NUT	ASTM A-194-2HM	F-594 TYPE 304
BOLT (ONLY 2 ½")	SAE J429 Gr.5	ASTM F593 TYPE 304
STUD (3" & 4")	SAE J429 Gr.5	A193 B8
THRUST BEARING	R-PTFE	R-PTFE
STEM	AISI 1018 / AISI 12L14 / A105	AISI 316
STEM SEAL	R-TFE	R-TFE
STOP SCREW (3" & 4")	AISI 1045	AISI 304
STUD STOP SCREW (ONLY 2 ½")	AISI 1045	AISI 304
STOP PLATE	AISI 1018/AISI 1020	AISI 1018/AISI 1020
LOCK WASHER (ONLY 2 ½")	AISI 1060	AISI 304
BELLEVILLE WASHER	AISI 1075	AISI 304
STEM NUT (3" & 4")	ASTM A-194-2HM	F-594 TYPE 304
FOLLOWER	AISI 416	AISI 416
HANDLE (3" & 4")	A-216-WCB	A-351-CF8M
HANDLE RETENTION SCREW (3" & 4")	AISI 1045	AISI 304
HANDLE (ONLY 2 ½")	AISI 1018/AISI 1020	AISI 316
HANDLE NUT (ONLY 2 ½")	ASTM A-194-2HM	F-594 TYPE 304

Service Conditions:

CONDITION	CARBON STEEL	STAINLESS STEEL
ANSI CLASS #	300	300
OPERATION TEMPERATURE	-20 to 100°F (-29 to 38°C)	-20 to 100°F (-29 to 38°C)
MAX. ALLOWABLE WORKING PRESSURE	740psi (52 Kg/cm2)	720psi (50.6 Kg/cm2)
MAXIMUM PRESSURE TEST	1125 psi (78 Kg/cm2)	1100 psi (76 Kg/cm2)

Note : Always consider the maximum pressure allowed by the soft elements as seats and seals.



8. Complete the welding (If you're welding with gas or bronze, don't apply the flame directly to the body).
9. Reassemble the Valve. Remember ball only can be assembled with the valve in the closed position.
10. Tight the bolts which join the body with its ends, with next recommended torques:

Bolt Diameter	Recommended Torque of Three piece Body Nuts			
	Carbon Steel		Stainless Steel	
	(lb*plg)	Nm	(lb*plg)	Nm
7/16"	480-540	54.2-61.0	336-384	38.0-43.4
1/2"	1062-1416	120-160	708-973	80-110
9/16"	1536-2050	173-231	1075-1435	121-162

11. If you remove the actuator bracket, place it again together with the coupling element. Be sure all assembling is aligned in the center. If the actuator is not aligned and/or the coupling element is not perpendicular with the valve, the whole element could not work properly and/or media could leaks through the stem.

Threaded Valves:

Depending of the conditions or the used technique, screw in or disassemble the complete Valve following the instructions of point 5 of the previous section (taking away the 6 screws) and screwing in each cover in its corresponding extreme. Reassemble the Valve following the instructions of the points 9 and 11 of the previous section.

Caution: Do not install your valve in a high vibrating piping system, as the bolts which joint the the body and ends can get loose. If necessary, add a lock washer in everyone of these bolts (nut's side) to avoid them to move as result of vibration.

Caution: After installation, some burrs can stay inside the pipe line. If they are not removed, they can produce scratches in the seats and ball, resulting in leaks. Always clean the pipeline after installation, to remove strange agents.

The valve will operate with no leaks and low torque for a long life if it is operated under its design parameters. The torque for a new valve depends of its size and the material of the seats installed. Please consult our printed or multimedia catalogs or visit our website: www.worcester.com.mx at your convenience, to get this data.

After proper installing (or maintenance) and before operation, always follow the safety instructions at the end of this document.

MAINTENANCE :

After operation and depending of the usage's conditions, Valve may need maintenance. Remember that your Valve has one-year warranty, if it is still in that period, please contact with your distributor, do not try to fix it or you may lost the warranty. Use ONLY originals RHINO Spare Parts, it assures you Valve will work according with its specifications. You can request them through the wide net of distributors all around the World.

Stem:

Although the Stem's design includes a self-adjustable system, compensatory of the wear and the contractions and expansions produced by thermal changes, if the valve presents leak for this section you must consider the next recommendations:



- a) If your Valve has an actuator installed, check if it is aligned with the stem through the couple. A disaligned actuator can produce lateral pressure on the stem, which will have repercussions on leaks.
- b) Tighten lightly the adjusting nut of the stem until the leak stops. Remember tightening too much this nut will increase the torque of the Valve and can damage stem seal, reducing its life. If after you tightened the nut a leak continues, follow the next steps:
- c) Shutoff the line where the valve is installed, verifying that no pressure and no dangerous media remains in the pipe and inside the valve. Proceed to disassemble the valve following instructions of steps 5 and 6 of the “Installation” section.

Caution: Ball Valves can retain pressurized media in the body cavity when closed. Take care when disassembling. Always open Valve to relieve pressure prior to disassembly.

Caution : Always depressurize, disconnect and disengaged automation components installed on the valve before you work on it.

- d) Change the thrust bearing and stem’s seals, taking out the handle, the adjustment’s nut, the lock nut, the Belleville washers and the follower.
- e) Reassemble the stem’s elements in an inverse way you took them out. Tighten lightly to the stem’s adjusting nut (once you have installed the valve on line, you can give the final adjustment).
- f) Finish the Valve following steps 9 to 11 of “installation” section.

Note: Be careful with the seats, do not mistreat or scratch them, otherwise you will need to replace them.

Seals:

In case of leak between the body and ends, you may consider next recommendations:

- a) Verify that the nuts of the bolts that join the three parts of the body are tightened as per the recommended torque. Tighten them as necessary, if this happens often, it may be due to an excessive line vibration. We might suggest you to include “Expansion Joints” in the line to avoid it. If this is not possible or enough, you can install pressure nuts in each nut to reduce this effect.
- b) If leak persists, disassemble the Valve according to the steps 5 and 6 of the “installation” section.
- c) Reassemble the Valve placing new seals according to the steps 9 to 11 the “installation” section.

Internal Leak:

If the Valve presents internal leak (the fluid goes through it in closed position) it may be due to a wear on the seats or a scratch in the seats or ball. We suggest considering the next recommendations:

- a) Some solid materials can clog between seat and ball. Operate the Valve several occasions to try to unblock these residues.
- b) If your Valve has an actuator installed, check if it completes its own route and close perfectly, if not, maybe the Valve has an elevated torque or the actuator may be disaligned or defective. Verify that the voltage and/or air pressure of automation components is correct. If it is necessary, we recommend removing the actuator and manually operating the valve to check if this is the cause of the leak.
- c) If the valve has an excessive torque, try loosening lightly the stem nut. If this is not enough or a stem leak appears, you must change the stem seals.
- d) If the leak persists, disassemble the Valve following the steps 5 and 6 of the “installation” section.